

IN SILICO EVALUATION OF A CELL-FREE PROCESS FOR THE PRODUCTION OF AVIAN INFLUENZA VACCINE

Marina S. R. Silva^{1*}, Marco Antonio Stephano² & Adriano R. Azzoni¹

¹ Departamento de Engenharia Química, Escola Politécnica, Universidade de São Paulo, São Paulo, SP, Brazil.

² Departamento de Tecnologia Bioquímica-Farmacêutica, Faculdade de Ciências Farmacêuticas, Universidade de São Paulo, São Paulo, SP, Brazil.

*Corresponding author email address: marinasaviolli@usp.br

ABSTRACT

Avian Influenza is a highly contagious viral disease that affects wild and domestic birds, and occasionally affects mammals, including humans. Currently, one of the biggest concerns of poultry farmers is to keep their production free of this disease, to avoid the sanitary slaughter of their birds. The establishment of vaccine belts using safe and effective vaccines against avian flu, produced through a cost-effective technology would be a desirable alternative. In this context, recombinant protein synthesis technology via Cell-Free platforms has become an interesting option due to its versatility, rapid production and high productivity. Here we present a simulation and initial techno-economic analysis of a Cell-Free process for the production of an avian veterinary vaccine based on influenza virus hemagglutinin protein. Cell extract obtained from cultivated DF-1, immortal fibroblasts derived from embryonic chicken, was simulated. The Cell-Free reactor using the Cytomim system for hemagglutinin production showed that optimizations regarding the cell-free reaction are still necessary to reduce production cost. In particular, the high cost of raw materials in the Cell-Free reactor makes the protein production cost still expensive for veterinary use, with an estimated cost of \$2.16 per dose. Although different unit operation scenarios were not yet simulated, so far our study indicated that RNA polymerase accounts for most (64%) of the raw material cost. In this context, the installation of an adjacent in-house RNA polymerase production plant may be interesting to overcome the high cost of this enzyme.

Keywords: Cell-free technology 1. Process simulation 2. Avian influenza 3. Veterinary vaccines 4.

INTRODUCTION

The Cell-Free Protein Synthesis (CFPS) is an emerging technology that uses cellular extract for the expression of a recombinant protein, in this system all reaction resources are directed towards protein synthesis, as there is no need to keep the cell alive. The fact that protein synthesis is not inside the cell makes the environment more diluted, improving protein folding, reducing unwanted reactions and increasing diffusion rates.¹ Furthermore, cell culture and extract preparation require less monitoring than *in vivo* production.² When choosing the cell extract, the protein to be synthesized must be taken into account. Like *in vivo* eukaryotic systems, eukaryotic extracts have the advantage of making post-translational modifications, such as glycosylation, phosphorylation and correct folding, despite having a higher cost than prokaryotic extracts.¹

One of the biggest challenges in CFPS technology is process scale-up. In many cases reported in literature, reaction volumes are limited to tens of microliters, yielding only tens of micrograms of protein per batch. A method for the scale up of the cell-free reaction that uses a stirred tank in batch mode using an energy regeneration system with oxidative phosphorylation (Cytomim) was developed, allowing control in the rate of gas exchange, addition of reagents and sampling during the reaction.³ In addition, it can be used in batch, semi-continuous or continuous mode. The use of the stirred tank allowed the scale up of the cell-free reaction to the volume of 1 L (and more). The major limitation of this system was the foaming caused by the cell extract components. However, this limitation was easily overcome using concentrations of 0.001% antifoam agent.³

The CFPS is still a technology under development, especially regarding large-scale synthesis of proteins. So far we know, all of the articles published in literature are focused on the production of pharmaceutical proteins for human use.^{1,2} The viability of large scale production in these cases is reported to be largely limited to a significant increase in the product yield and also the recycling of high-cost components such as plasmid DNA (pDNA).² Here, present a techno-economic analysis of a CFPS process to produce recombinant hemagglutinin from influenza avian virus (group A) using DF-1 chicken fibroblast cells extracts. The objective is to evaluate the potential of the CFPS platform for the production of veterinary vaccines against avian flu, as an alternative strategy to rapidly respond to possible bird influenza outbreaks.

1. MATERIAL & METHODS

SuperPro Designer v12.0 (Intelligen, USA) was employed to model and simulate the process scenario and the economic assessment of the process. The simulation of the process was based on the CFPS production of 30 million doses of vaccine per year, each dose containing 25 µg of Hemagglutinin antigen. A plant lifetime of 15 years was defined, regarding depreciation.

Cell culture for extract production: Since no kinetic data from DF-1 cells adapted to serum free medium was found in literature, cell culture simulations were performed with data from DF-1 adherent cell with a maximum growth rate of 0.029 h⁻¹,⁴ using serum-free medium supplemented with glutaMAX at 37°C. The cell inoculum was added at a cell density of 1x10⁵ cells/ml and cell growth

was designed to reach a final cell density of 8×10^6 cells/mL before the cell lysis. The cell culture section was built with two seed bioreactors operating in batch mode and one main bioreactor operating in fed-batch³.

Extract Preparation: After cell growth, cells were collected and washed with HEPES-KOH pH 7.5 buffer and a 2X permeate volume in a TFF operation, and concentrated using the maximum concentration factor. The cell-free system allows for this rapid production, however, there is a need to decouple the cell extract production from the cell-free reaction. Therefore, lyophilization of the cell extract after cell growth has been proposed. For the lyophilization of the cellular extract, filling equipment, lyophilizer, bulk removal and tank to dilute the cellular extract were added in the preparation of the extract. The cells were lysed in a high-pressure homogenizer at 800 bar and the extract was diluted with TRIS Buffer for entry into the cell-free reaction.

Cell-free synthesis The cell-free reaction synthesis was carried out using a batch stirred tank with Cytomim energy regeneration system. Cytomim system included 130 mM potassium glutamate, 10 mM ammonium glutamate, 8 mM magnesium glutamate, 33 mM sodium pyruvate, 1.5 mM spermidine, 1 mM putrescine, and 4 mM sodium oxalate. 1.2 mM ATP; 0.85 mM each of GTP, UTP, and CTP; 34 Ag/mL folic acid; 170.6 Ag/mL of *E. coli* tRNA mixture; 13.3 Ag/mL plasmid; 100 Ag/mL T7 RNA polymerase; 5 AM L-[U-14C]-leucine; 2 mM each of 20 unlabeled amino acids; 0.33 mM NAD; 0.26 mM CoA; and 0.24 volume extract (16.84 L). Considering the stoichiometry of the reaction, 0.5 of oxygen was added to the reactants and 0.5 of CO₂ to the products. It was considered a production of 386 mg/L of soluble hemagglutinin in 5 hours of reaction.³

Purification: Upon leaving the cell-free reaction, the solution was washed and concentrated in a TFF system with PBS. Then the solution containing the protein was dissolved in 8 M urea to enter the Talon metal affinity chromatography column, containing Co²⁺ ions. The protein was eluted with 150 mM imidazole. To remove the imidazole, a TFF with PBS was used.

2. RESULTS & DISCUSSION

The simulations of the production of the avian influenza virus hemagglutinin protein and their economic analyzes were developed using the SuperPro Designer software. The estimated annual production was 30 million doses, it was considered that a dose should contain 25 µg of hemagglutinin, that is, the estimated protein production was approximately 0.75 kg per year.

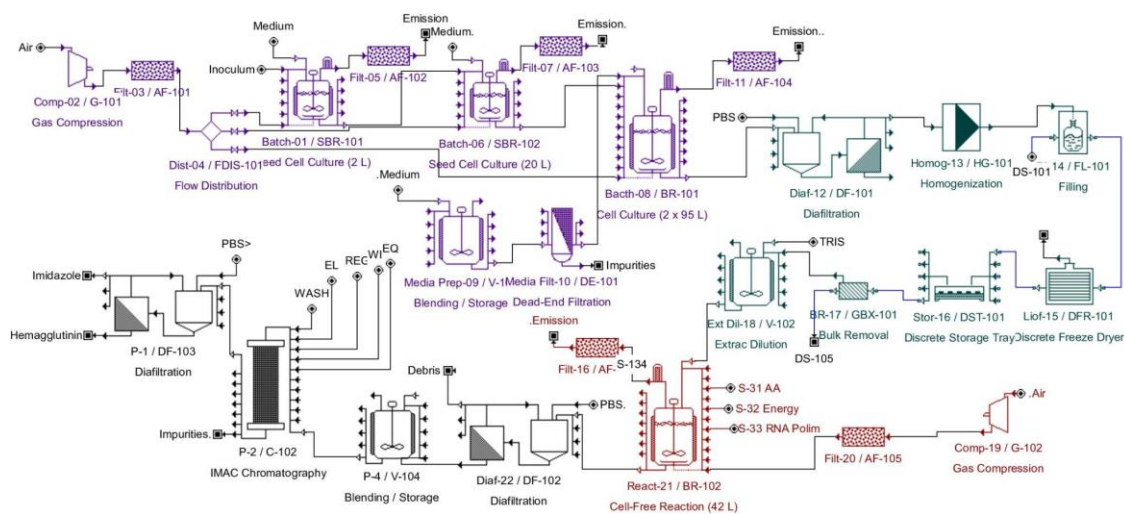

Figure 1 Flowsheet of the baseline scenario for the simulation of the upstream process for Hemagglutinin production.

In the economic analysis, the simulation had an investment capital of \$30.345 million and an annual operation cost of \$65.286 million/year, composed of \$14.655 million/year for cell culture, \$1.673 million/year for cell extract preparation, \$47.801 million/year for Cell-Free reaction and \$1.157 million/year for purification. The production cost of a dose containing 25 µg of hemagglutinin was \$2.16. The cost of raw materials was responsible for the high annual operating cost (Figure 2).

The reagent with the highest cost was RNA polymerase, responsible for 63% of the cost of Materials. An alternative to reducing the cost of this raw material is the implementation of an adjacent in-house plant. The polymerase is the highest-cost compound and has to be added in relatively high quantities. Moreover, the cell-free protein synthesis still needs to optimize the use of resources. Optimizations in cell-free reaction kinetics enable efficient use of available resources, increasing target protein production as well as reducing production costs.

It is important to point out that, in the case of a vaccine for animal use, production costs still need to be reduced to produce a vaccine against avian influenza to be economically viable. However, the cell-free protein synthesis still needs to optimize the use of resources. Optimizations in cell-free reaction kinetics enable efficient use of available resources, increasing target protein

production as well as reducing production costs. Moreover, the cell-free system allows for greater flexibility and controllability, facilitating the production of customized and on-demand products.

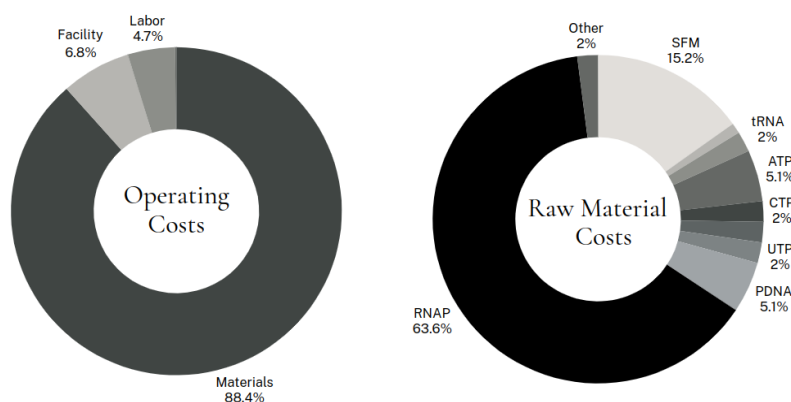

Figure 2 Composition of the production cost of Hemagglutinin.

3. CONCLUSION

Bioprocess scenario was simulated for the production of hemagglutinin for an avian influenza vaccine in a cell-free process, where the economic viability of processes was evaluated. The operation cost of the plant was estimated at \$59.5 million/year, for the production of 30 million doses per year, with a cost of \$2.16 dollars per dose (25 µg of hemagglutinin). So far, the simulation has not yet reached the expected low cost for the economic viability of a veterinary vaccine against avian influenza for birds to be used as vaccine belts. However, some costs can still be optimized, mainly of raw materials, which were used with the retail market price. The in house production of a few high cost reagents, such as RNA polymerase and plasmid DNA can also be evaluated for the reduction of the production costs.

REFERENCES

1. Chiba et al. Cell-free protein synthesis advances on production process for biopharmaceuticals and immunobiological products, **Biotechniques**, v. 70(2), p. 126-133, 2021.
2. THAORE, V. et al. Techno-Economic Assessment of Cell-Free Synthesis of Monoclonal Antibodies Using CHO Cell Extracts, **Processes**, v. 8, 2020.
3. VOLOSHIN, A.M.; SWARTZ, J.R. Chapter 12 - Large Scale Batch Reactions for Cell-Free. IN: Cell-Free Protein Synthesis: Methods and Protocols. Ed **John Wiley & Sons**, p. 207 - 235, 2007.
4. Lin, J.; Yi, X.; Zhuang, Y. Medium optimization based on comparative metabolomic analysis of chicken embryo fibroblast DF-1 cells, **RCS Advances**, v. 9, p. 27369–27377, 2019.
5. LOMBA et al. Serum-Free Suspension Adaptation of HEK-293T Cells: Basis for Large-Scale Biopharmaceutical Production, **Brazilian Archives of Biology and Technology**. Vol.64: e21200817, 2021.
6. BRÖDEL, A. K. et al. Chapter 7 - Cell-Free Protein Synthesis Systems Derived from Cultured Mammalian Cells. IN: Structural Proteomics: High Throughput Methods, **Methods in Molecular Biology**, p. 129 -n 140, vol. 1261, 2015.

ACKNOWLEDGEMENTS

The authors thank São Paulo Research Foundation (FAPESP), grant 2018/14047-2. This study was financed in part by the Coordenação de Aperfeiçoamento de Pessoal de Nível Superior – Brasil (CAPES) – Finance Code 001.